



MANUAL PALLET TRUCKS



PANTHER

PANTHER INOX

WEIGHING SCALE PALLET TRUCK (WSP 2200)

CUSTOMISED PALLET TRUCK

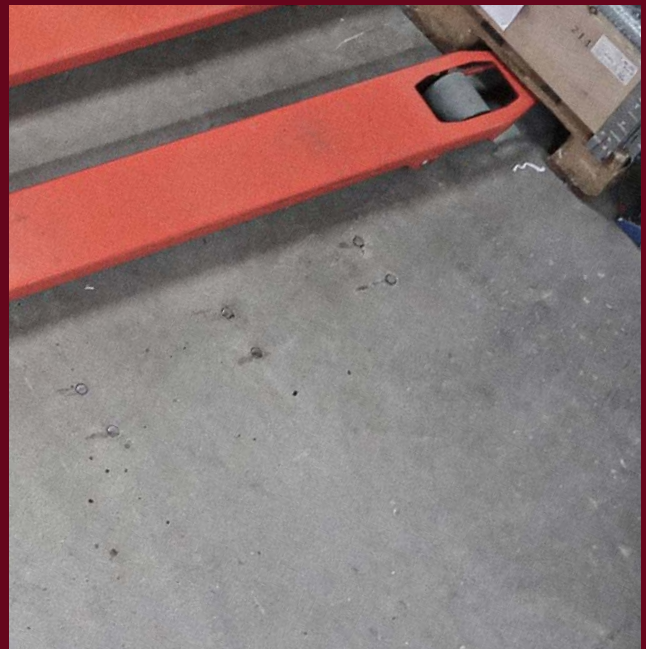

Manual pallet trucks

Our manual pallet trucks are constructed of high-quality steel and are designed to give the operator a safe, solid and efficient solution for pallet transportation.

The strong construction ensures a long operating life with very low maintenance costs.

The elegant design with rounded corners reduces risk of causing damages, while moving goods and pallets around - both to surrounding objects, the pallets and other valuable items. In addition, the ergonomically correct handle gives the operator a relaxed hold and proper working posture.

The special-designed wheels ensure minimum starting power and allow you to transport pallets

with heavy loads smoothly and with little physical efforts.

Our manual pallet truck is available with different fork lengths and spans, as well as it comes in stainless steel and as explosion proof.

We also have our Panther Silent, which is a manual pallet truck with completely smooth and silent movement. And our manual pallet truck with weighing scale.

Less strokes to raise to full height
(permanent quick lift pump)

Custom fork length

Strong construction
(no through-going axle in the A-frame)

Ergonomically correct handle



Movable parts with
tight tolerances without
metallic contact



Fixed/movable (articulating)
steering wheel axle

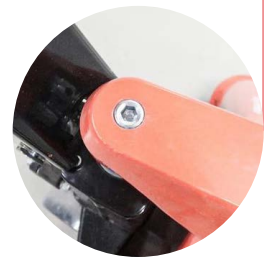

The fork height is
adjustable to save pump
strokes.

The Panther - Danish quality since 1975

The Panther, launched in 1998, is an improved version of our original pallet truck, first introduced in 1975.

Quality has always been the ground pillar of our product assortment, and the strong constructions result in extremely long operating lives. The Panther is no exception to this. It is tested with up to 46,000 lifts and we have customers with Panthers from the 1980s still operating.



The Panther has smooth and silent movements due to the construction, with minimum friction of all movable parts (does not rattle) and tight tolerance. In addition, it has an ergonomic handle and rounded corners to protect both the operator and the surroundings.

It is very easy to manoeuvre due to the wheels and construction: Minimum starting power, short length behind the forks, low own weight and tight turning angle. In combination, this makes it possible to operate the Panther in confined areas.

The Panther is available with different fork lengths and widths, as well as with different wheels types. The capacity ranges from 1600 kg. up to 3000 kg.

We use a special oil for all products, which is tested in cold atmospheres down to at least -10 degrees C.

Panther inox

We offer the highest quality stainless steel products on the market.

To give our customers the best experience, our stainless steel pallet trucks are designed from the bottom to minimise risks of rust and bacterial contamination.

This is evident in the closed forks, closed triangle and smooth surfaces. The Panther Inox and Inox Plus are developed for environments with high hygienic standards, or for wet and otherwise aggressive environments, which require high level of resistance and aggressive cleaning.

All surfaces are easy to clean and the chassis is constructed of AISI 316L acid-resistant steel to avoid rust.

Our stainless steel products are electropolished and very suitable for the food industry and pharmaceutical industry.

*Please refer to our Inox brochure for more information.

We use a special oil for all products, which is tested in cold atmospheres down to at least -10 degrees C.



Pallet truck with weighing scale

With the weighing scale pallet truck, WSP 2200, you can transport and weigh goods in the same working process.

It is a valuable and very time-efficient solution for customers in e.g. storage areas, who need to inspect incoming or off-shipping goods.

The weighing system has a high accuracy. It has four strong weighing cells, and a solid and very well protected display. The display is user-friendly and has logic and simple settings. It is centrally located, which gives the operator easy access to read the weight.



The construction of the pallet truck is strong and solid, and as with all of our pallet trucks, is very easy to operate and maintain.

We use a special oil for all products, which is tested in cold atmospheres down to at least -10 degrees C.

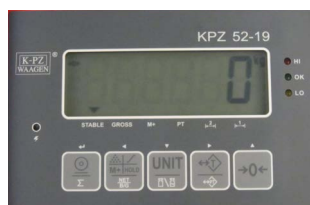

Can weigh up to 2200 kg.

Panther customised

If you have special requests for fork lengths and/or fork span, we have our manual customised Panther.

Fork lengths from 600 mm to 2400 mm

Fork span from 350 mm to 1100 mm

In addition, it is available with different wheel types, with drum forks, as well as it has adjustable fork height.

We use a special oil for all products, which is tested in cold atmospheres down to at least -10 degrees C.



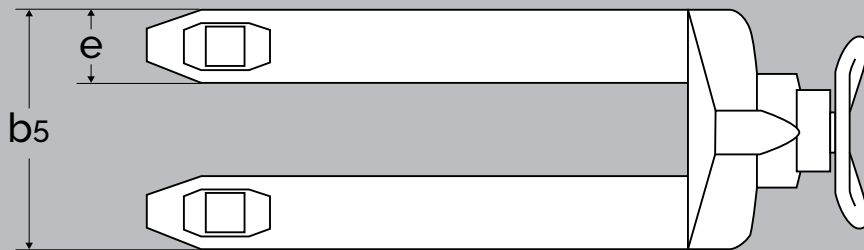
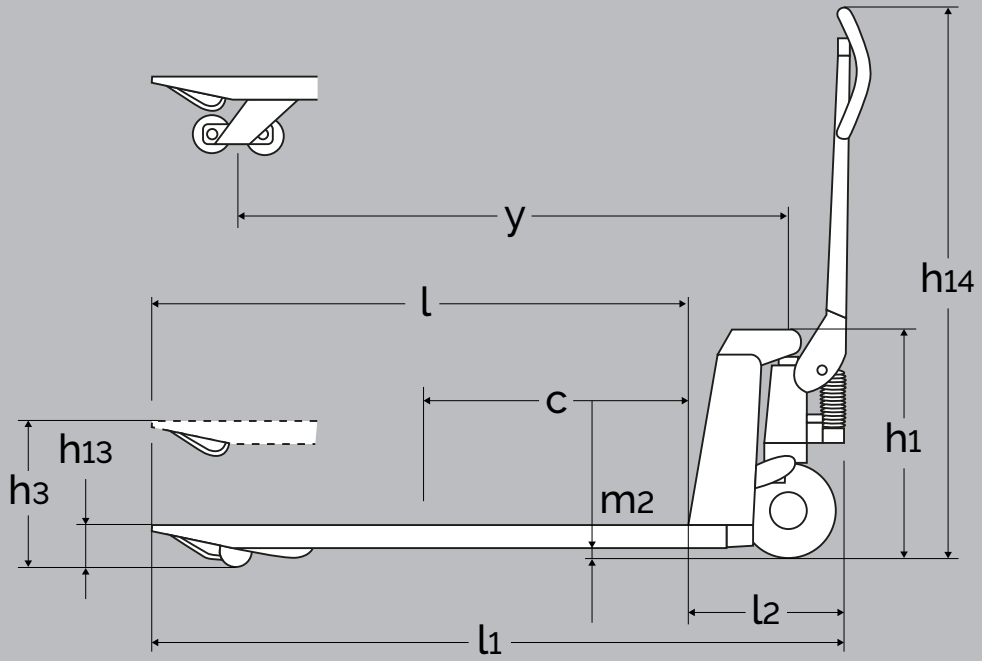

PRODUCT (measured in mm)		Panther 1672	Panther 1682	Panther 2572	Panther 2582	Panther 3072	Panther 3082
Capacity in kg		1600 kg		2500 kg		3000 kg	
Lifting height	h_3	$h_{13} + 120$					
Fork length	l	600, 810, 970, 1140		600, 810, 915, 970, 1066, 1140, 1220, 1520, 1800, 2000, 2400*		600, 810, 915, 970, 1140, 1220, 1520	
Overall height	h_1	$h_{13} + 413$					
Fork span	b_5	450		520, 680		520, 680	
Lenght without forks	l_2	335					
Overall length	l_1	$l + 335$					
Fork width	e	125		160			
Wheelbase	y	$l + 25$					
Overall height	h_{14}	1170					
Lowered height - adjustable	h_{13}	75 to 83	85 to 93	75 to 83	85 to 93	75 to 83	85 to 93
Load centre	c	$l/2$					
Ground clearance	m_2	$h_{13} + 47$					
Turning angle of the wheels		220°					
Fork wheels - single		Ø75 x 68	Ø85 x 68	Ø75 x 90	Ø85 x 90		
Fork wheels - tandem				Ø75 x 68	Ø85 x 68	Ø75 x 68	Ø85 x 68
Steering wheel		Ø200 x 50					
Weight		59 kg (450 x 1140)		62 kg (520 x 1140)		68 kg (520 x 1140)	

*Reduced capacity 1500 kg.

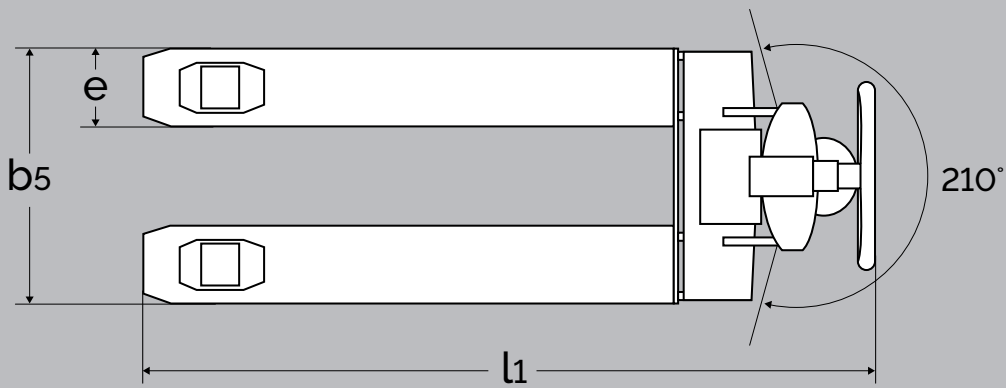
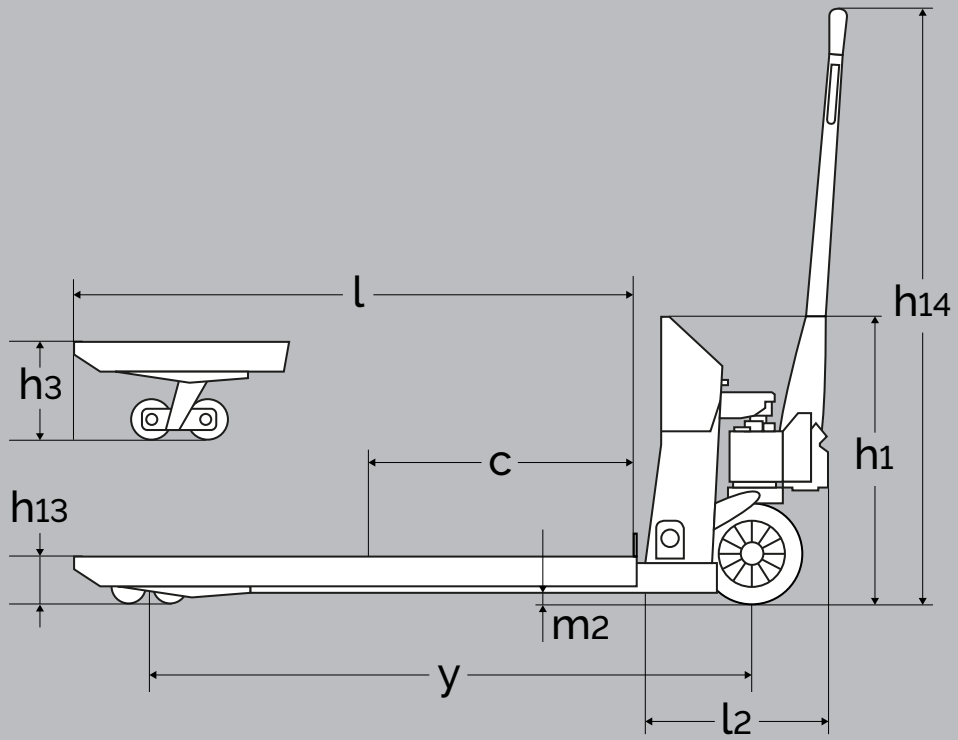

Capacity in kg		2200 kg
Lifting height	h_3	200
Fork length	l	1150
Overall height	h_1	590
Fork span	b_5	560
Length without forks	l_2	415
Overall length	l_1	1570
Fork width	e	171
Wheelbase	y	1200
Overall height	h_{14}	1220
Lowered height - adjustable	h_{13}	92
Load centre		$l/2$
Ground clearance	m_2	12
Turning angle of the wheels		210°
Fork wheels		Tandem polyurethane
Steering wheel		Ø200 rubber
Weight		99 kg

Technical Specifications

- Can transport/weigh up to 2,200 kg.
- Four strong weighing cells, IP68.
- Weighing cell accuracy 99,95%.
- Graduation: 1,0 kg.
- Backlight display with clear figures (30 mm).
- Tare function (gross and net weight).
- Counting and zero setting.
- Summation of several weighings.
- Up to 250 operational hours per charge.
- Battery indicator.
- Lowering function controlled by lowering valve.
- High-pressure relief valve prevents overload.
- Lubricating nipples in the most important movable parts.

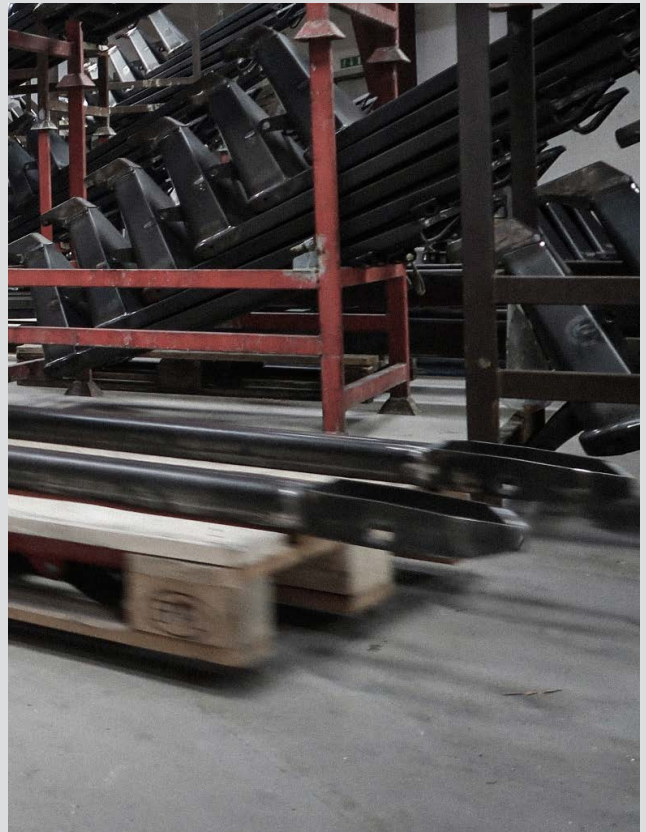
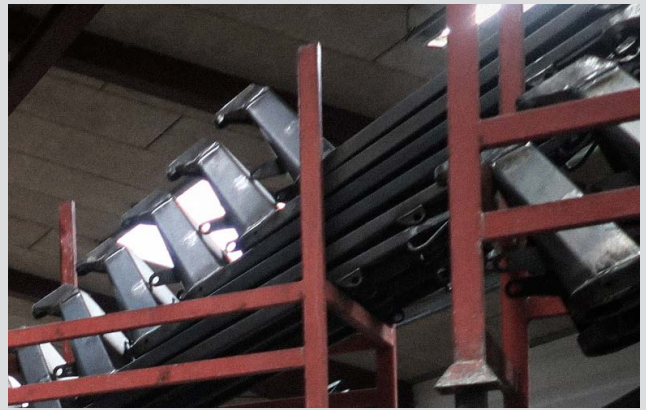

Ergonomic Lifting Equipment

Logitrans A/S

+45 76 88 16 00

info@logitrans.com

www.logitrans.com

